

Sentronic SCT series current sensors provide a smaller, cost-effective solution for AC, DC current measurement in industrial and automotive applications. SCT provide abundant variants of output modes.

### Features and Benefits:

- Open-loop current sensor using Hall effect IC
- Single 5V supply
- Response time ~3us, bandwidth 170Khz
- Options for uni-direction DC or bi-direction AC
- Analog output proportional to AC or DC currents
- Current detection range: ±50A - ±200A
- Operating temperature range: -40 °C to +125°C  
(150A: -40 °C to +105°C; 200A/250: -40 °C to +85°C)
- QVO (Zero current output):
  - xR: QVO ratiometric to supply voltage  $V_{CC}$ , Fixed Gain  
 $V_{QVO} = V_{CC}/2$  or  $V_{CC}/10$
  - xF: Fixed QVO and Gain  
 $V_{QVO} = 2.5$  or  $0.50$  Volts
- Good linearity, accuracy and temperature drift
- Supper low power loss: 100  $\mu\Omega$  internal conductor resistance

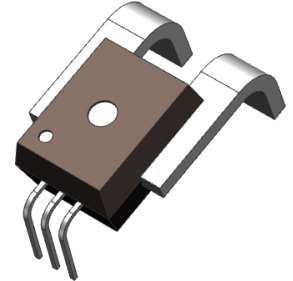

### Applications:

- Inverters and UPS
- Switching Power Supply
- Motor Controller

### Pinout Table:

Number	Name	Description
1	$V_{CC}$	Device power supply
2	GND	Signal ground
3	$V_{OUT}$	Analog output signal
4	$I_{P+}$	Terminal+ for current being measured
5	$I_{P-}$	Terminal- for current being measured

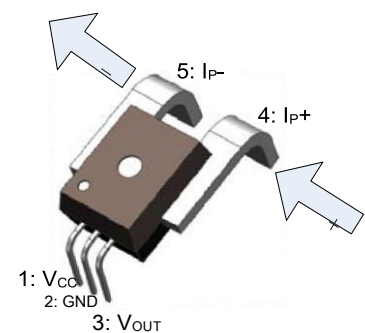

### Principle of Open-loop current sensor:

The open-loop current sensor use Ampere's law which means the magnetic field in space around an electric current is proportional to the electric current which serves as its source. The magnetic flux density  $B$  is generated by the primary current  $I_P$ , hall element output voltage will change with the magnetic field. In the linear region of the hysteresis curve,  $B$  is proportional to:

$$B(I_P) = K * I_P \quad (\text{constant } k)$$

Hall output voltage is express as:

$$V_H = (R_H/d) * I * K * I_P \quad (\text{constant } k, R_H, d, I)$$

$$V_H = K_1 * I_P \quad (\text{constant } k_1)$$

Hall IC calculates the primary current by amplifying  $V_H$  to obtain a voltage.

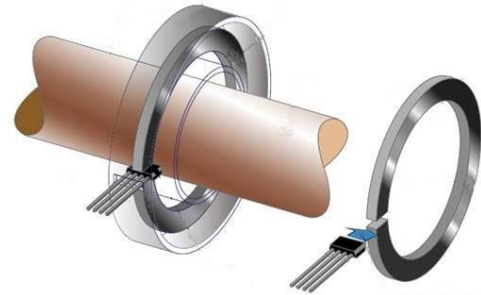

### Application Circuit:

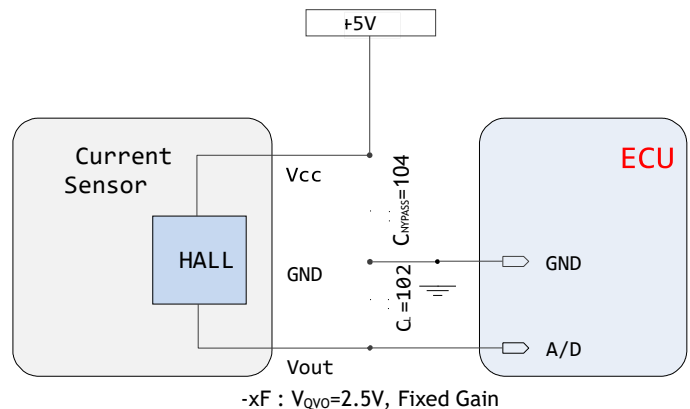
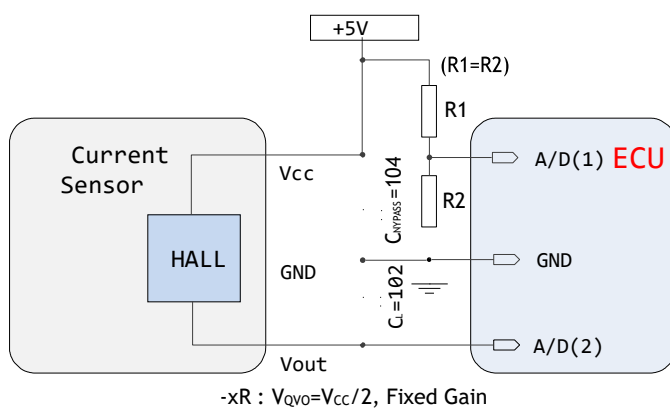

*\*VCC BYPASS capacitor must be close to Device power supply pin*

### Part Number Format:

S CT xxx x x

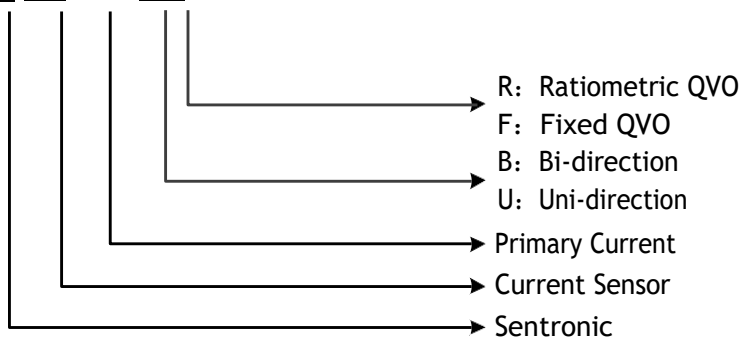

### Ordering Information:

Part number	QVO $V_{OUT(Q)}$ (V)	Primary Current $I_P$ (A)	Sensitivity $Sens_{(typ.)}$ (mV/A)	Package	MPQ (PCS)	MOQ (PCS)
SCT050BR	$V_{CC}/2$	$\pm 50$	40	PFF	40	400
SCT050BF	2.50			PSF		
SCT050UR	$V_{CC}/10$	50	80	PSS	40	400
SCT050UF	0.50			SMT		
SCT100BR	$V_{CC}/2$	$\pm 100$	20	PFF	40	400
SCT100BF	2.50			PSF		
SCT100UR	$V_{CC}/10$	100	40	PSS	40	400
SCT100UF	0.50			SMT		
SCT150BR	$V_{CC}/2$	$\pm 150$	13.33	PFF	40	400
SCT150BF	2.50			PSF		
SCT150UR	$V_{CC}/10$	150	26.67	PSS	40	400
SCT150UF	0.50			SMT		
SCT200BR	$V_{CC}/2$	$\pm 200$	10	PFF	40	400
SCT200BF	2.50			PSF		
SCT200UR	$V_{CC}/10$	200	20	PSS	40	400
SCT200UF	0.50			SMT		
SCT250BR	$V_{CC}/2$	$\pm 250$	8	PFF	40	400
SCT250BF	2.50			PSF		
SCT250UR	$V_{CC}/10$	250	16	PSS	40	400
SCT250UF	0.50			SMT		

\*Touch Sentronic plant for specific output variants

### Packaging information:

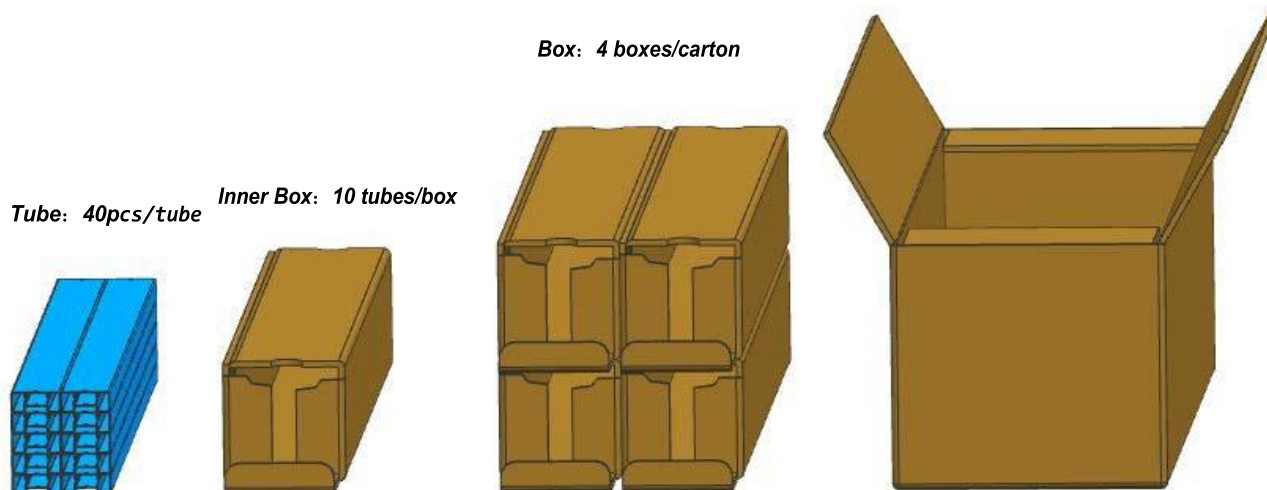

### Absolute Maximum Ratings

Characteristic	Symbol	Rating	Unit
Supply Voltage	$V_{CC}$	-0.3 to 6.5	V
Output Voltage	$V_{OUT}$	0.15 to $V_{CC}-0.15$	V
Output Current	$I_{OUT}$	±40	mA
Operating Temperature	$T_A$	-40 to 150	°C
Max Junction Temperature	$T_J$	165	°C
Storage Temperature	$T_S$	-55 to 165	°C

### Common Operating Characteristics

Valid at  $T_A = -40^{\circ}\text{C}$  to  $125^{\circ}\text{C}$ , and  $V_{CC}=5\text{V}$ , 0.1uF bypass capacitor unless otherwise specified

Parameter	Symbol	Condition	Min	Typ.	Max	Unit
Supply Voltage	$V_{CC}$		4.5	5	5.5	V
Supply Current	$I_{CC}$	$R_L \geq 10\text{K}\Omega$		13	18	mA
Power on Delay	$T_{PO}$	$T_A=25^{\circ}\text{C}$		80		μs
QVO Ratiometric Error (-R)	$E_r$		-0.3		0.3	%
Zero Current Output Voltage	$V_{QVO}$	SCTxxxBR	$T_A = 25^{\circ}\text{C}$	$V_{CC}/2$		V
		SCTxxxBF		2.50		
		SCTxxxUR		$V_{CC}/10$		
		SCTxxxUF		0.50		
Output voltage Range @ $I_P$	$V_{OUT}-V_{QVO}$	SCTxxxBR		±2		
		SCTxxxBF				
		SCTxxxUR		4		
		SCTxxxUF				
Output Load Resistance	$R_L$	$V_{OUT}$ to $V_{CC}$ or GND	2			KΩ
Output Load Capacitance	$C_L$	$V_{OUT}$ TO GND	6		100	nF
Response Time	$t_{RESPONSE}$	$T_A=25^{\circ}\text{C}$ , $C_L=1\text{nF}$ , $I_P$ step=50% of $I_{P+}$ , 90% input to 90% output		3		μs
Internal Bandwidth	BW	Small signal -3dB, $C_L=1\text{nF}$ , $T_A=25^{\circ}\text{C}$	120	170		KHz
DC Output Impedance	$R_{OUT}$	$T_A = 25^{\circ}\text{C}$	-	3	-	Ω

### ISOLATION CHARACTERISTICS

Characteristic	Symbol	Notes	Rating	Unit
Dielectric Strength Test Voltage	$V_{ISO}$	Agency type-tested for 60 seconds per UL standard 60950-1, 2nd Edition	4800	VAC
Working Voltage for Basic Isolation	$V_{WFSI}$	For basic (single) isolation per UL standard 60950-1, 2nd Edition	990	VDC or $V_{pk}$
			700	$V_{rms}$
Working Voltage for Reinforced Isolation	$V_{WFRI}$	For reinforced (double) isolation per UL standard 60950-1, 2nd Edition	636	VDC or $V_{pk}$
			450	$V_{rms}$

### B050 Performance Characteristics

Valid at  $T_A = -40^{\circ}\text{C}$  to  $125^{\circ}\text{C}$ , and  $V_{CC} = 5\text{V}$ , unless otherwise specified

Parameter	Symbol	Condition	Min	Typ.	Max	Unit
<b>Nominal Performance</b>						
Current Sensing Range	$I_P$		-50		50	A
Sensitivity	$\text{Sen}_{TA}$	@ $V_{CC}=5\text{V}$		40		mV/A
<b>Accuracy Performance</b>						
Sensitivity Error	$E_{\text{Sens}}$	@ $T_A=25^{\circ}\text{C}; V_{CC}=5\text{V}$	-1		1	%
Electrical Offset Error	$V_{OE}$	$I_P=0\text{A}, T_A=25^{\circ}\text{C}$	-4	$\pm 3$	4	mV
		$I_P=0\text{A}, T_A=-40^{\circ}\text{C} \sim 125^{\circ}\text{C}$	-20	$\pm 8$	20	mV
Magnetic Offset Error	$I_{OM}$	$I_P=0\text{A}, T_A=25^{\circ}\text{C}$ , after excursion of 50A		125	250	mA
Offset Current	$I_{\text{OFFSET}}$	$T_A=25^{\circ}\text{C}$			0.3	A
Linearity Error	$\text{Lin}_{ERR}$	Of full rang	-1	0.5	1	%
Total Output Error	$E_{\text{TOT(HT)}}$	Full scale of $I_P, T_A=25^{\circ}\text{C} \sim 125^{\circ}\text{C}$	-2		2	%
	$E_{\text{TOT(LT)}}$	Full scale of $I_P, T_A=-40^{\circ}\text{C} \sim 25^{\circ}\text{C}$	-2		2	%

### U050 Performance Characteristics

Valid at  $T_A = -40^{\circ}\text{C}$  to  $125^{\circ}\text{C}$ , and  $V_{CC} = 5\text{V}$ , unless otherwise specified

Parameter	Symbol	Condition	Min	Typ.	Max	Unit
<b>Nominal Performance</b>						
Current Sensing Range	$I_P$		0		50	A
Sensitivity	$\text{Sen}_{TA}$	@ $V_{CC}=5\text{V}$		80		mV/A
<b>Accuracy Performance</b>						
Sensitivity Error	$E_{\text{Sens}}$	@ $T_A=25^{\circ}\text{C}; V_{CC}=5\text{V}$	-1		1	%
Electrical Offset Error	$V_{OE}$	$I_P=0\text{A}, T_A=25^{\circ}\text{C}$	-4	$\pm 3$	4	mV
		$I_P=0\text{A}, T_A=-40^{\circ}\text{C} \sim 125^{\circ}\text{C}$	-20	$\pm 8$	20	mV
Magnetic Offset Error	$I_{OM}$	$I_P=0\text{A}, T_A=25^{\circ}\text{C}$ , after excursion of 50A		80	150	mA
Offset Current	$I_{\text{OFFSET}}$	$T_A=25^{\circ}\text{C}$			0.15	A
Linearity Error	$\text{Lin}_{ERR}$	Of full rang	-1	0.5	1	%
Total Output Error	$E_{\text{TOT(HT)}}$	Full scale of $I_P, T_A=25^{\circ}\text{C} \sim 125^{\circ}\text{C}$	-2		2	%
	$E_{\text{TOT(LT)}}$	Full scale of $I_P, T_A=-40^{\circ}\text{C} \sim 25^{\circ}\text{C}$	-2		2	%

## B100 Performance Characteristics

Valid at  $T_A = -40^{\circ}\text{C}$  to  $125^{\circ}\text{C}$ , and  $V_{CC} = 5\text{V}$ , unless otherwise specified

Parameter	Symbol	Condition	Min	Typ.	Max	Unit
<b>Nominal Performance</b>						
Current Sensing Range	$I_P$		-100		100	A
Sensitivity	$\text{Sens}_{TA}$	@ $V_{CC}=5\text{V}$		20		mV/A
<b>Accuracy Performance</b>						
Sensitivity Error	$E_{\text{Sens}}$	@ $T_A=25^{\circ}\text{C}; V_{CC}=5\text{V}$	-1		1	%
Electrical Offset Error	$V_{OE}$	$I_P=0\text{A}, T_A=25^{\circ}\text{C}$	-4	$\pm 3$	4	mV
		$I_P=0\text{A}, T_A=-40^{\circ}\text{C} \sim 125^{\circ}\text{C}$	-20	$\pm 8$	20	mV
Magnetic Offset Error	$I_{OM}$	$I_P=0\text{A}, T_A=25^{\circ}\text{C}$ , after excursion of 100A		200	300	mA
Offset Current	$I_{\text{OFFSET}}$	$T_A=25^{\circ}\text{C}$	-		0.5	A
Linearity Error	$\text{Lin}_{\text{ERR}}$	Of full rang	-1	0.5	1	%
Total Output Error	$E_{\text{TOT(HT)}}$	Full scale of $I_P$ , $T_A=25^{\circ}\text{C} \sim 125^{\circ}\text{C}$	-2		2	%
	$E_{\text{TOT(LT)}}$	Full scale of $I_P$ , $T_A=-40^{\circ}\text{C} \sim 25^{\circ}\text{C}$	-2		2	%

## U100 Performance Characteristics

Valid at  $T_A = -40^{\circ}\text{C}$  to  $125^{\circ}\text{C}$ , and  $V_{CC} = 5\text{V}$ , unless otherwise specified

Parameter	Symbol	Condition	Min	Typ.	Max	Unit
<b>Nominal Performance</b>						
Current Sensing Range	$I_P$		0		100	A
Sensitivity	$\text{Sens}_{TA}$	@ $V_{CC}=5\text{V}$		40		mV/A
<b>Accuracy Performance</b>						
Sensitivity Error	$E_{\text{Sens}}$	@ $T_A=25^{\circ}\text{C}; V_{CC}=5\text{V}$	-1		1	%
Electrical Offset Error	$V_{OE}$	$I_P=0\text{A}, T_A=25^{\circ}\text{C}$	-4	$\pm 3$	4	mV
		$I_P=0\text{A}, T_A=-40^{\circ}\text{C} \sim 125^{\circ}\text{C}$	-20	$\pm 8$	20	mV
Magnetic Offset Error	$I_{OM}$	$I_P=0\text{A}, T_A=25^{\circ}\text{C}$ , after excursion of 100A		100	150	mA
Offset Current	$I_{\text{OFFSET}}$	$T_A=25^{\circ}\text{C}$	-		0.25	A
Linearity Error	$\text{Lin}_{\text{ERR}}$	Of full rang	-1	0.5	1	%
Total Output Error	$E_{\text{TOT(HT)}}$	Full scale of $I_P$ , $T_A=25^{\circ}\text{C} \sim 125^{\circ}\text{C}$	-2		2	%
	$E_{\text{TOT(LT)}}$	Full scale of $I_P$ , $T_A=-40^{\circ}\text{C} \sim 25^{\circ}\text{C}$	-2		2	%

### B150 Performance Characteristics

Valid at  $T_A = -40^{\circ}\text{C}$  to  $105^{\circ}\text{C}$ , and  $V_{CC} = 5\text{V}$ , unless otherwise specified

Parameter	Symbol	Condition	Min	Typ.	Max	Unit
<b>Nominal Performance</b>						
Current Sensing Range	$I_P$		-150		150	A
Sensitivity	$\text{Sen}_{TA}$	@ $V_{CC}=5\text{V}$		13.33		mV/A
<b>Accuracy Performance</b>						
Sensitivity Error	$E_{\text{Sens}}$	@ $T_A=25^{\circ}\text{C}; V_{CC}=5\text{V}$	-1		1	%
Electrical Offset Error	$V_{OE}$	$I_P=0\text{A}, T_A=25^{\circ}\text{C}$	-4	$\pm 3$	4	mV
		$I_P=0\text{A}, T_A=-40^{\circ}\text{C} \sim 105^{\circ}\text{C}$	-20	$\pm 8$	20	mV
Magnetic Offset Error	$I_{OM}$	$I_P=0\text{A}, T_A=25^{\circ}\text{C}$ , after excursion of 150A		300	400	mA
Offset Current	$I_{\text{OFFSET}}$	$T_A=25^{\circ}\text{C}$			0.75	A
Linearity Error	$\text{Lin}_{\text{ERR}}$	Of full rang	-1	0.5	1	%
Total Output Error	$E_{\text{TOT(HT)}}$	Full scale of $I_P$ , $T_A=25^{\circ}\text{C} \sim 105^{\circ}\text{C}$	-2		2	%
	$E_{\text{TOT(LT)}}$	Full scale of $I_P$ , $T_A=-40^{\circ}\text{C} \sim 25^{\circ}\text{C}$	-2		2	%

### U150 Performance Characteristics

Valid at  $T_A = -40^{\circ}\text{C}$  to  $105^{\circ}\text{C}$ , and  $V_{CC} = 5\text{V}$ , unless otherwise specified

Parameter	Symbol	Condition	Min	Typ.	Max	Unit
<b>Nominal Performance</b>						
Current Sensing Range	$I_P$		0		150	A
Sensitivity	$\text{Sen}_{TA}$	@ $V_{CC}=5\text{V}$		26.67		mV/A
<b>Accuracy Performance</b>						
Sensitivity Error	$E_{\text{Sens}}$	@ $T_A=25^{\circ}\text{C}; V_{CC}=5\text{V}$	-1		1	%
Electrical Offset Error	$V_{OE}$	$I_P=0\text{A}, T_A=25^{\circ}\text{C}$	-4	$\pm 3$	4	mV
		$I_P=0\text{A}, T_A=-40^{\circ}\text{C} \sim 105^{\circ}\text{C}$	-20	$\pm 8$	20	mV
Magnetic Offset Error	$I_{OM}$	$I_P=0\text{A}, T_A=25^{\circ}\text{C}$ , after excursion of 150A		180	320	mA
Offset Current	$I_{\text{OFFSET}}$	$T_A=25^{\circ}\text{C}$			0.45	A
Linearity Error	$\text{Lin}_{\text{ERR}}$	Of full rang	-1	0.5	1	%
Total Output Error	$E_{\text{TOT(HT)}}$	Full scale of $I_P$ , $T_A=25^{\circ}\text{C} \sim 105^{\circ}\text{C}$	-2		2	%
	$E_{\text{TOT(LT)}}$	Full scale of $I_P$ , $T_A=-40^{\circ}\text{C} \sim 25^{\circ}\text{C}$	-2		2	%

## B200 Performance Characteristics

Valid at  $T_A = -40^{\circ}\text{C}$  to  $85^{\circ}\text{C}$ , and  $V_{CC} = 5\text{V}$ , unless otherwise specified

Parameter	Symbol	Condition	Min	Typ.	Max	Unit
<b>Nominal Performance</b>						
Current Sensing Range	$I_P$		-200		200	A
Sensitivity	$\text{Sens}_{TA}$	@ $V_{CC}=5\text{V}$		10		mV/A
<b>Accuracy Performance</b>						
Sensitivity Error	$E_{\text{Sens}}$	@ $T_A=25^{\circ}\text{C}; V_{CC}=5\text{V}$	-1		1	%
Electrical Offset Error	$V_{OE}$	$I_P=0\text{A}, T_A=25^{\circ}\text{C}$	-4	$\pm 3$	4	mV
		$I_P=0\text{A}, T_A=-40^{\circ}\text{C} \sim 85^{\circ}\text{C}$	-20	$\pm 6$	20	mV
Magnetic Offset Error	$I_{OM}$	$I_P=0\text{A}, T_A=25^{\circ}\text{C}$ , after excursion of 200A		400	500	mA
Offset Current	$I_{\text{OFFSET}}$	$T_A=25^{\circ}\text{C}$			1.0	A
Linearity Error	$\text{Lin}_{\text{ERR}}$	Of full rang	-1	0.5	1	%
Total Output Error	$E_{\text{TOT(HT)}}$	Full scale of $I_P$ , $T_A=25^{\circ}\text{C} \sim 85^{\circ}\text{C}$	-2		2	%
	$E_{\text{TOT(LT)}}$	Full scale of $I_P$ , $T_A=-40^{\circ}\text{C} \sim 25^{\circ}\text{C}$	-2		2	%

## U200 Performance Characteristics

Valid at  $T_A = -40^{\circ}\text{C}$  to  $85^{\circ}\text{C}$ , and  $V_{CC} = 5\text{V}$ , unless otherwise specified

Parameter	Symbol	Condition	Min	Typ.	Max	Unit
<b>Nominal Performance</b>						
Current Sensing Range	$I_P$		0		200	A
Sensitivity	$\text{Sens}_{TA}$	@ $V_{CC}=5\text{V}$		20		mV/A
<b>Accuracy Performance</b>						
Sensitivity Error	$E_{\text{Sens}}$	@ $T_A=25^{\circ}\text{C}; V_{CC}=5\text{V}$	-1		1	%
Electrical Offset Error	$V_{OE}$	$I_P=0\text{A}, T_A=25^{\circ}\text{C}$	-4	$\pm 3$	4	mV
		$I_P=0\text{A}, T_A=-40^{\circ}\text{C} \sim 85^{\circ}\text{C}$	-20	$\pm 6$	20	mV
Magnetic Offset Error	$I_{OM}$	$I_P=0\text{A}, T_A=25^{\circ}\text{C}$ , after excursion of 200A		200	250	mA
Offset Current	$I_{\text{OFFSET}}$	$T_A=25^{\circ}\text{C}$			0.5	A
Linearity Error	$\text{Lin}_{\text{ERR}}$	Of full rang	-1	0.5	1	%
Total Output Error	$E_{\text{TOT(HT)}}$	Full scale of $I_P$ , $T_A=25^{\circ}\text{C} \sim 85^{\circ}\text{C}$	-2		2	%
	$E_{\text{TOT(LT)}}$	Full scale of $I_P$ , $T_A=-40^{\circ}\text{C} \sim 25^{\circ}\text{C}$	-2		2	%

## B200 Performance Characteristics

Valid at  $T_A = -40^{\circ}\text{C}$  to  $85^{\circ}\text{C}$ , and  $V_{CC} = 5\text{V}$ , unless otherwise specified

Parameter	Symbol	Condition	Min	Typ.	Max	Unit
<b>Nominal Performance</b>						
Current Sensing Range	$I_P$		-200		200	A
Sensitivity	$\text{Sens}_{TA}$	@ $V_{CC}=5\text{V}$		10		mV/A
<b>Accuracy Performance</b>						
Sensitivity Error	$E_{\text{Sens}}$	@ $T_A=25^{\circ}\text{C}; V_{CC}=5\text{V}$	-1		1	%
Electrical Offset Error	$V_{OE}$	$I_P=0\text{A}, T_A=25^{\circ}\text{C}$	-4	$\pm 3$	4	mV
		$I_P=0\text{A}, T_A=-40^{\circ}\text{C} \sim 85^{\circ}\text{C}$	-20	$\pm 6$	20	mV
Magnetic Offset Error	$I_{OM}$	$I_P=0\text{A}, T_A=25^{\circ}\text{C}$ , after excursion of 200A		400	500	mA
Offset Current	$I_{\text{OFFSET}}$	$T_A=25^{\circ}\text{C}$			1.0	A
Linearity Error	$\text{Lin}_{\text{ERR}}$	Of full rang	-1	0.5	1	%
Total Output Error	$E_{\text{TOT(HT)}}$	Full scale of $I_P$ , $T_A=25^{\circ}\text{C} \sim 85^{\circ}\text{C}$	-2		2	%
	$E_{\text{TOT(LT)}}$	Full scale of $I_P$ , $T_A=-40^{\circ}\text{C} \sim 25^{\circ}\text{C}$	-2		2	%

## U200 Performance Characteristics

Valid at  $T_A = -40^{\circ}\text{C}$  to  $85^{\circ}\text{C}$ , and  $V_{CC} = 5\text{V}$ , unless otherwise specified

Parameter	Symbol	Condition	Min	Typ.	Max	Unit
<b>Nominal Performance</b>						
Current Sensing Range	$I_P$		0		200	A
Sensitivity	$\text{Sens}_{TA}$	@ $V_{CC}=5\text{V}$		20		mV/A
<b>Accuracy Performance</b>						
Sensitivity Error	$E_{\text{Sens}}$	@ $T_A=25^{\circ}\text{C}; V_{CC}=5\text{V}$	-1		1	%
Electrical Offset Error	$V_{OE}$	$I_P=0\text{A}, T_A=25^{\circ}\text{C}$	-4	$\pm 3$	4	mV
		$I_P=0\text{A}, T_A=-40^{\circ}\text{C} \sim 85^{\circ}\text{C}$	-20	$\pm 6$	20	mV
Magnetic Offset Error	$I_{OM}$	$I_P=0\text{A}, T_A=25^{\circ}\text{C}$ , after excursion of 200A		200	250	mA
Offset Current	$I_{\text{OFFSET}}$	$T_A=25^{\circ}\text{C}$			0.5	A
Linearity Error	$\text{Lin}_{\text{ERR}}$	Of full rang	-1	0.5	1	%
Total Output Error	$E_{\text{TOT(HT)}}$	Full scale of $I_P$ , $T_A=25^{\circ}\text{C} \sim 85^{\circ}\text{C}$	-2		2	%
	$E_{\text{TOT(LT)}}$	Full scale of $I_P$ , $T_A=-40^{\circ}\text{C} \sim 25^{\circ}\text{C}$	-2		2	%

## B250 Performance Characteristics

Valid at  $T_A = -40^{\circ}\text{C}$  to  $85^{\circ}\text{C}$ , and  $V_{CC} = 5\text{V}$ , unless otherwise specified

Parameter	Symbol	Condition	Min	Typ.	Max	Unit
<b>Nominal Performance</b>						
Current Sensing Range	$I_P$		-250		250	A
Sensitivity	$\text{Sen}_{\text{STA}}$	@ $V_{CC}=5\text{V}$		8		mV/A
<b>Accuracy Performance</b>						
Sensitivity Error	$E_{\text{Sens}}$	@ $T_A=25^{\circ}\text{C}; V_{CC}=5\text{V}$	-1		1	%
Electrical Offset Error	$V_{\text{OE}}$	$I_P=0\text{A}, T_A=25^{\circ}\text{C}$	-4	$\pm 3$	4	mV
		$I_P=0\text{A}, T_A=-40^{\circ}\text{C} \sim 85^{\circ}\text{C}$	-20	$\pm 6$	20	mV
Magnetic Offset Error	$I_{\text{OM}}$	$I_P=0\text{A}, T_A=25^{\circ}\text{C}$ , after excursion of 200A		500	640	mA
Offset Current	$I_{\text{OFFSET}}$	$T_A=25^{\circ}\text{C}$			1.2 5	A
Linearity Error	$\text{Lin}_{\text{ERR}}$	Of full rang	-1	0.5	1	%
Total Output Error	$E_{\text{TOT(HT)}}$	Full scale of $I_P$ , $T_A=25^{\circ}\text{C} \sim 85^{\circ}\text{C}$	-2		2	%
	$E_{\text{TOT(LT)}}$	Full scale of $I_P$ , $T_A=-40^{\circ}\text{C} \sim 25^{\circ}\text{C}$	-2		2	%

## U250 Performance Characteristics

Valid at  $T_A = -40^{\circ}\text{C}$  to  $85^{\circ}\text{C}$ , and  $V_{CC} = 5\text{V}$ , unless otherwise specified

Parameter	Symbol	Condition	Min	Typ.	Max	Unit
<b>Nominal Performance</b>						
Current Sensing Range	$I_P$		0		250	A
Sensitivity	$\text{Sen}_{\text{STA}}$	@ $V_{CC}=5\text{V}$		16		mV/A
<b>Accuracy Performance</b>						
Sensitivity Error	$E_{\text{Sens}}$	@ $T_A=25^{\circ}\text{C}; V_{CC}=5\text{V}$	-1		1	%
Electrical Offset Error	$V_{\text{OE}}$	$I_P=0\text{A}, T_A=25^{\circ}\text{C}$	-4	$\pm 3$	4	mV
		$I_P=0\text{A}, T_A=-40^{\circ}\text{C} \sim 85^{\circ}\text{C}$	-20	$\pm 6$	20	mV
Magnetic Offset Error	$I_{\text{OM}}$	$I_P=0\text{A}, T_A=25^{\circ}\text{C}$ , after excursion of 200A		250	320	mA
Offset Current	$I_{\text{OFFSET}}$	$T_A=25^{\circ}\text{C}$			0.6 5	A
Linearity Error	$\text{Lin}_{\text{ERR}}$	Of full rang	-1	0.5	1	%
Total Output Error	$E_{\text{TOT(HT)}}$	Full scale of $I_P$ , $T_A=25^{\circ}\text{C} \sim 85^{\circ}\text{C}$	-2		2	%
	$E_{\text{TOT(LT)}}$	Full scale of $I_P$ , $T_A=-40^{\circ}\text{C} \sim 25^{\circ}\text{C}$	-2		2	%

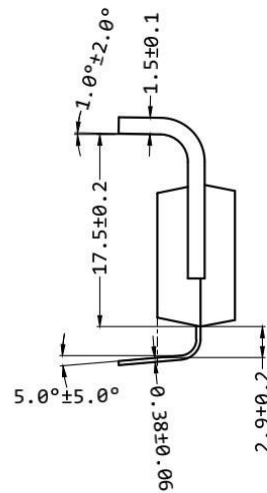
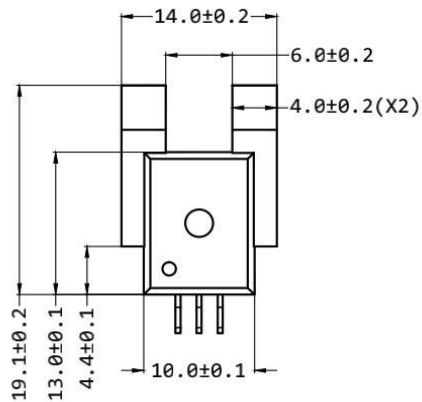
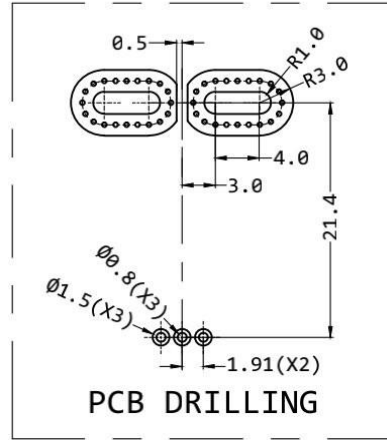
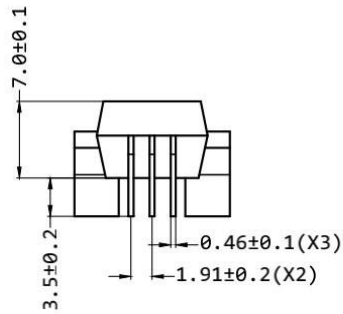

Terminals	Definitions
1	VCC
2	GND
3	VOUT
4	IP+
5	IP-

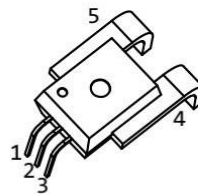

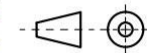
Tag	Severall	Change the content	Signature	Date	Model: SCT series Current sensor		
					Describe:		
Drawn					Phase Marker  Weight Proportion A 4.23g 1:1		
Check							
Audit					Material:		
Approval					Version: V01 Page 1 Total of 1 page		

## Performances Parameters Definitions:

### ● Quiescent Voltage Output (QVO):

In the quiescent state (no significant magnetic field,  $B=0G$ ), Current Sensor Output Voltage  $V_{QVO}$

-XR:  $V_{QVO}$  has a constant ratio to the supply voltage;

$$V_{QVO} = V_{CC}/2 \text{ or } V_{QVO} = V_{CC}/10$$

-XF:  $V_{QVO}$  and Gain is fixed and doesn't change with supply voltage;

$$V_{QVO} = 2.5V \text{ or } V_{QVO} = 0.5V$$

● **Sensitivity(Sens):** Sens is the slope of the straight line ;  $V_{OUT} = V_{QVO} + 2 \times I_P/I_{P\_MAX}$   
Sens is programmed to: **Sens =  $2/I_{P\_MAX}$**

### ● Offset with Temperature:

Due to internal component tolerances and thermal considerations, the Quiescent Voltage Output (QVO) may drift from its nominal value through the operating ambient temperature (TA).

### Sensitivity with temperature:

Due to the influence of internal temperature compensation coefficient, the sensitivity will change through the whole working temperature, and be different from the expected value at room temperature.

### ● Error - Electrical Offset Voltage:

The noise of HALL element and internal operational amplifier cause the error.

### ● Error - Magnetic Offset:

The magnetic offset is the consequence of any current on the primary side. It's defined after a stated excursion of primary current.

### ● Error - Total offset voltage:

The zero offset voltage is the output voltage when the primary current is zero, with ideal value:  $V_{QVO} = V_{CC}/2$  (or fixed 2.5V). The difference between  $V_{QVO}$  and ideal value is named Total offset voltage error. This offset error can be attributed to the zero-point offset voltage (due to the ASIC internal QVO adjusted resolution), magnetic offset, temperature drift, and hysteresis

### ● Response Time:

The time between the primary current signals (IPN) reaches 90% of its final value and when the sensor output signal reaches 90%. See figure1.



● **Total Output Error  $E_{TOT}$ :**

Error between the device measurement current and Applied current ( $I_P$ ), which is defined as the difference between the ideal output voltage and the actual output voltage divided by the ideal sensitivity:

$$E_{TOT(I_P)} = \frac{V_{I_{OUT}(I_P)} - V_{I_{OUT}(ideal)(I_P)}}{Sens_{(ideal)} \times I_P}$$

$$V_{I_{OUT}(ideal)(I_P)} = V_{I_{OUT}(Q)} + (Sens_{(ideal)} \times I_P)$$

At relatively high currents,  $E_{TOT}$  is mainly due to sensitivity errors; while at relatively low currents,  $E_{TOT}$  is mainly due to offset voltage errors ( $V_{OE}$ ).

Actually, when the  $I_P$  approaches zero, the  $E_{TOT}$  approaches infinity due to offset voltage error.

● **Important notes**

1. Wrong wiring may cause sensor damage. After the sensor is connected to the 5V power supply, the measured current passes through the direction of the sensor current terminal, and the corresponding voltage value can be measured at the output end.

2.-BR mode:  $V_{OUT}$  is proportional to  $V_{CC}$ ,

$$V_{OUT} = V_{CC}/2 + 2 \times I_P / I_{P(MAX)}$$

Supply voltage change will cause  $V_{OUT}$  change by ratio.

For example:  $V_{CC}$  range: 4.75V~5.25V;

$V_{QV0}$  output range at 0A: 2.375V~2.625V。

$V_{OUT(IPMAX)}$  output range at  $I_{pmax}$ : 4.275V~4.725V。

-BF mode:  $V_{QV0}=2.5V$ ,  $V_{OUT}$  sensitivity is fixed:

$$V_{OUT} = 2.5 + 2 \times \frac{I_P}{I_{P(MAX)}}$$

For example:  $V_{CC}$  range: 4.75V~5.25V;  $V_{QV0}$  output range at 0A: 2.5V;

$V_{OUT(IPMAX)}$  output range at  $I_{pmax}$ : 4.5V。

$V_{QV0}$  and  $V_{OUT(IPMAX)}$  don't change with  $V_{CC}$  fluctuat